

HYUNDAI
POWER PRODUCTS

ELECTRIC LOG SPLITTER
HFBE10T105

ORIGINAL INSTRUCTIONS

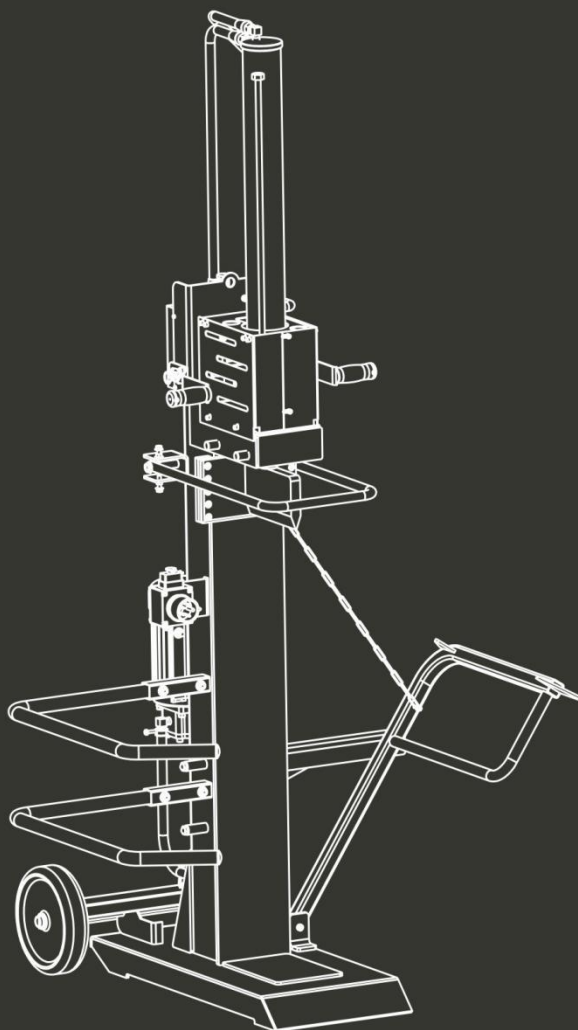

WARNING: Read thoroughly the instruction manual before using.

CONTENTS

1. SAFETY INSTRUCTIONS.....	3
2. YOUR PRODUCT.....	9
3. ASSEMBLY.....	16
4. OPERATION.....	18
5. MAINTENANCE AND REPAIR.....	25
6. DISPOSAL.....	25
7. DECLARATION OF CONFORMITY.....	26
8. WARRANTY.....	27
9. PRODUCT FAILURE.....	28
10. WARRANTY EXCLUSIONS.....	29

1. SAFETY INSTRUCTIONS

GENERAL INFORMATION

We wish you much joy and success in working with your new machine.

Note: The manufacturer of this equipment shall not be liable in accordance with the applicable product liability law for damage caused by this device through:

Improper treatment;

- Failure to comply with the operating instructions;
- Repair by unauthorized personnel;
- Installation and replacement of non-original parts;
- Improper use;

Failure of the electrical system due to non-compliance with electrical requirements and VDE specifications 0100, DIN 57113/VDE0113.

We recommend:

Read the entire operating instructions before assembly and getting started with the device. This operating manual should help you become familiar with your machine and use it as intended.

The operating manual includes important information on how to work safely, correctly and economically with the machine and how to avoid hazard, save repair costs, reduce downtimes and increase the reliability and service life of the machine.

In addition to the safety regulations of this operating manual, you must follow the national provisions applicable to the operation of the machine.

Keep the operating manual close to the machine, in a plastic cover protected against dirt and moisture. It must be read by every operator before starting work and carefully followed. Work at the machine may be done only persons who are instructed on using the machine and the associated hazards. The minimum age specified should be observed.

Check all parts for any transportation damage after unpacking them. In case of complaints, the supplying carrier must be notified immediately. Later claims will not be accepted. Check the shipment for completeness.

Familiarize yourself with the device before using it by referring to the operating manual. Use only original parts for accessories, wear parts and spare parts. You will receive spare parts from your specialist dealer.

Indicate our article numbers as well as type and model of the device in your orders.

GENERAL SAFETY INFORMATION

Manual concerning your safety:

WARNING: When using electric tools, you should follow these basic safety precautions in order to reduce the risk of fire, electric shock and personal injury.

- Please read all instructions before operating this tool.
- Operator must receive necessary training and instruction from a qualified person before handling the tool.
- Use the tool only for the intended use. Misuse (such using material other than log) can damage the tool and cause accidents and injuries.
- Split only logs with a maximum length of 1060 mm.
- Split only logs with a minimum diameter of 70 mm and a maximum diameter of 400mm.

- The splitting operation of the machine is designed to be activated by one person. While there is the possibility that additional operators could be working with the machine (e.g. for loading and unloading), only one operator should activate splitting operations.
- The machine shall not be used by children.
- Wear personal protective equipment (safety goggles/protective visor, safety gloves, and safety shoes) to protect yourself from possible injury.
- Before starting work, hydraulic pipes and hoses shall be inspected and the stopping devices shall be tested.
- The working area shall be free from obstructions; before installation and operation, clear the working area. Keep the working area free from obstructions, e.g. logs, split wood, etc.
- Stop the machine before cleaning or making adjustments.
- Never leave the machine unattended while it is running. If you leave the machine, even for a short time, remove the power supply or any possible cause of accidental start-up.
- Never try to split logs larger than those indicated in the technical specifications. This could be dangerous and may damage the machine.
- Break wood in the direction of the grain, do not place wood across the log splitter and leave it in that position for splitting; it may be dangerous and may seriously damage the machine.
- Never force the log splitter for more than 5 seconds keeping the cylinder under pressure in the attempt to split excessively hard wood. After this time interval, the oil under pressure is overheated and the machine could be damaged. It is thus better to stop and rotate the log by 90° to see whether it can be split in a different position. In any case, if you are not able to split the log, this means that its hardness exceeds the capacity of the machine and thus that log should be discarded so as not to damage the log splitter.
- Never place your hands on moving parts of the machine when it is turned on.
- Observe all safety and hazard instructions at the machine.
- Keep all safety and hazard instructions at the machine completely in a legible condition.
- The safety devices on the machine must not be dismantled or destroyed.
- Check mains supply lines. Do not use a defective power cable.
- Before starting up, check for proper functioning of the two-hand operation.
- The operator must be at least 18 years old. Apprentices must be at least 16 years old, but may work at the machine only under supervision.
- Wear safety gloves when working.
- Caution when working: Risk of injury to fingers and hands when using the splitting tool.
- To split heavy or bulky parts, use appropriate supporting implements.
- Carry out refitting, adjustment and cleaning, as well as maintenance and service, only when the motor is turned off. Disconnect the mains plug!
- Installations, repairs and maintenance work on the electrical installation may be performed only by qualified personnel.
- All protective and safety equipment must be re-installed immediately after repair and maintenance work is completed.
- The setting on the hydraulic valve and the control levers may not be changed. Risk of accident and destruction of the hydraulic components!
- When leaving the workplace, turn off the motor. Disconnect the mains plug!
- Provide for adequate lighting.

- In case of danger, turn off the machine and disconnect the mains plug!
- No other person should be in the work area.
- Never split logs containing nails, wire or other objects.
- Already split wood and wood chips create a dangerous work area. There is a risk of stumbling, slipping or falling. Keep the work area tidy at all times.
- The log splitter may not be operated in the transport position.

INTENDED USE

The machine conforms to the current EC Machinery Directive.

- The hydraulic log splitter may be used only in the “standing mode”, logs may be split only in an upright state and along the grain direction.
- Never split the log when it is lying down or across the grain direction.
- The safety, work and maintenance instructions of the manufacturer as well as the dimensions indicated in the technical data must be followed.
- The relevant accident prevention regulations and other generally accepted safety rules must be followed.
- The machine may be used, serviced or re-paired only by people who are familiar with it and are instructed about the hazards. Independent modifications to the machine
- Exclude liability of the manufacturer for resulting damage.
- The machine may be used only with original accessories and tools of the manufacturer.
- Any other use is considered improper. The manufacturer does not assume liability for resulting damage; the associated risk is solely borne by the plant operator

ACCIDENT PREVENTION RULES

- The machine may be operated only by qualified personnel who are thoroughly familiar with the contents of this operating manual.
- Prior to start-up, the integrity and perfect functionality of the safety devices must be checked.
- Prior to start-up, you should also familiarize yourself with the control mechanisms of the machine, following the operating instructions.
- The specified performance of the machine may not be exceeded. The machine may never be used for any purpose other than that intended.
- According to the laws of the country in which the machine is used, the staff must wear the specified work clothes, wherein one must not wear wide, flapping garments, belts, rings and necklaces; long hair should be tied back as far as possible.
- The workplace should always be neat and clean, and the tools, accessories and wrenches should all be within reach.
- When cleaning or servicing the machine, it may never be connected to the mains supply.
- It is strictly forbidden to operate the machine without the safety devices or with disabled safety mechanisms.
- It is strictly forbidden to remove or modify safety equipment.
- Do not carry out maintenance or adjustment measures before carefully reading this operating manual.
- The plan given here for regular maintenance must be observed both for safety reasons and for efficient operation of the machine.

- The safety labels should always be clean and legible and be followed precisely to avoid accidents, but if the signs are damaged or lost or belong to parts that were exchanged, they must be replaced by new original signs to be requested from the manufacturer and attached at the designated places.
- In the case of fires, dry chemical extinguishing agents must be used. Fires at the machine may not be extinguished with a water jet due to risk of short-circuit.
- If the fire cannot be immediately extinguished, one has to pay attention to the spilled fluids.
- In case of persistent fire, the oil tank or pressurized systems may explode: therefore, make sure that you do not come in contact with the leaking liquids.

DISMANTLING AND DISPOSAL

- The machine does not contain any health or environmentally harmful substances, since it was built entirely from materials that are recyclable or can be disposed of in the normal way.
- For disposal, you should consult specialist firms or a qualified professional who is aware of the possible risks, has read these instructions and follows them carefully.
- If the machine has reached the end of its service life, the following approach is adopted in compliance with all industrial safety standards specified:
- Interrupt the power supply (electric or PTO),
- Disconnect all power cords and transfer to a specialized collection point by following the latest relevant national provisions.
- Empty the oil tank; deliver the oil in sealed containers to a collection point by following the latest relevant national provisions.
- Deliver all other parts of the machine to a scrap collection point by following the latest relevant national provisions.
- Make sure that each and every part is disposed of in compliance with the latest relevant national provisions.

RESIDUAL RISKS

The machine has been built in accordance with the state of the art and recognized safety standards. Nevertheless, individual residual risks can occur when working.

- Risk of injury to fingers and hands from the splitting tool when improperly leading or supporting the wood.
- Injuries from flying workpiece due to improper guidance or support.
- Risk of electric shock when using improper mains supply cables.
- Furthermore, latent residual risks can persist in spite of all measures adopted.
- Residual risks can be minimized if safety instructions and proper use as well as the operating manual are followed altogether.

TRANSPORTATION/STORAGE

Transport with forklift trucks/lifting carts:

Before delivery, the machine should be secured with steel tapes and securely mounted on a pal-let. The machine is protected by a plastic sheet.

To lift it off the pallet, several persons or technical resources are required.

NOTE: The center of gravity of the log splitter is high risk of tipping over!

Transport by crane:

For transport using the hook, the crane lifting eye on the upper part of the machine should be used.

Never lift on the splitter blade!

Storage conditions:

Please adhere to the following specifications:

- Dry, covered storage location
- Max. humidity 80%
- Temperature range from -20 °C to + 60 °C

The machine should operate under the following environmental conditions:

- Min. Max. Recommended

	minimum	maximum	recommended
Temperature	5 °C	40 °C	16 °C
Humidity	-	95 %	70 %

At ambient temperatures below 5°C, the machine should run at idle for about 5 minutes, so that the hydraulic system reaches the operating temperature.

INSTALLATION

- Prepare the workplace where you want to install the machine. Create enough space for safe, trouble-free working.
- The machine is designed to work on flat surfaces and must be erected on a level, solid base.

START-UP

Make sure that the machine is assembled completely and properly. Check the following before each use:

- The main cables for defects (cracks, cuts, etc.),
- The machine for any damage,
- Whether all screws are tightened,
- The hydraulics for leaks and
- The oil level.
- that the guides are lubricated with grease

Check the direction of run of the motor. When the splitter arm is not in the upper position, move the splitter blade to the top position using the return bracket or the handles. If the splitter arm is already at the topmost position, activate the splitting mechanism by moving the two levers down.

This moves the splitting arm downwards.

If the splitter blade does not move despite pressing the handles or the return bracket, Please check the direction of the motor or check the connection between pump and the motor.

Never run the motor in the wrong direction of rotation! This inevitably leads to the destruction of the pumping system, and thus, no guarantee can be claimed.

CAUTION!

Before start-up, loosen the filler plug (fig. 7).

Never forget to loosen the filler plug!

Otherwise, the air in the system is compressed and relaxed again and again, leading to the destruction of the seals of the hydraulic circuit and rendering the log splitter unusable.

In this case, the seller and the manufacturer dissociate themselves from any guarantee claims.

Turning on/off

Press the green button to turn on.

Press the red button to turn off.

Note: before every use, check the on/off switch unit for proper functioning by turning on and off once.

Securing against restart in case of power outage (zero voltage trigger)











In the case a power outage, accidental disconnection of the mains plug or defective fuse, the machine switches off automatically. To restart, press the green button on the control unit once again.

Modifications of any kind to the machine are prohibited!

Before servicing or when the split-ting wedge gets stuck, disconnect the machine from the mains.

The machine should never be left unattended, unless it was unplugged from the mains!

SYMBOLS

	Read manual before operation
	Use safety footwear
	Use work gloves
	Wear eye protection
	Use hearing protection
	No trespassing
	No smoking in the working area
	Only the operator may stand within the operating range of the machine. Keep non-involved persons, as well as domestic and farm animals, out of the hazard area (minimum distance: 5m)
	Keep your work space tidy! Untidiness can lead to accidents
	Only the operator may stand within the operating range of the machine.

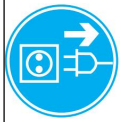

Caution! Switch off the engine before repair, maintenance and cleaning. Unplug the mains plug.



Do not remove jammed trunks with your hands.



Danger of bruising and injury from sharp edges; never touch danger areas when the cleaver is moving.

2. YOUR PRODUCT

Description

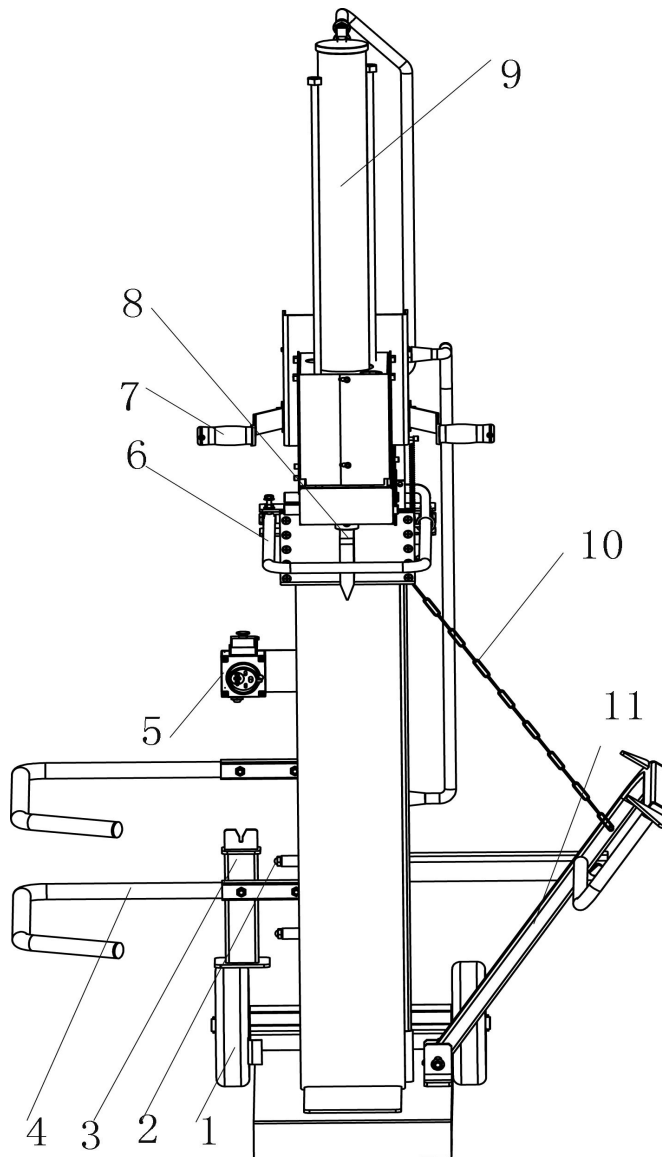

1-Wheels,
2-Inspection window,
3-Cylinder fixing part,
4-Side retaining arm,
5-Switch(3.7kw/230v/50HZ),
6-Return bracket,

7-Operation handle,
8-Splitting knife,
9-Cylinder,
10-Chain,
11-Lifting device.

Technical Data

Engine	Electrical motor
Input power(P1)	3.7kW
Voltage	230V~/50Hz
Motor speed	2800/min
Operating mode	S6/40%
Splitting force	10ton
Weight	169kg
Protection class	I
Cutting length	1060mm
Size of log	70-400mm
IP number	IP54
Hydraulic pressure	Max. 22MPa
Sound power level	91dB(A)

The specified values are emission levels and do not necessarily represent safe workplace values. Although there is a correlation between emission and emission levels, it can't be inferred with certainty whether or not additional precautions are necessary. Factors which affect the current emission level at the workplace include the nature of the working space, other noise sources, such as the number of machines and other adjacent operations. The allowed working values may vary from country to country. Merely, the information should enable the user to make an assessment of hazard and risk.

Wiring diagram

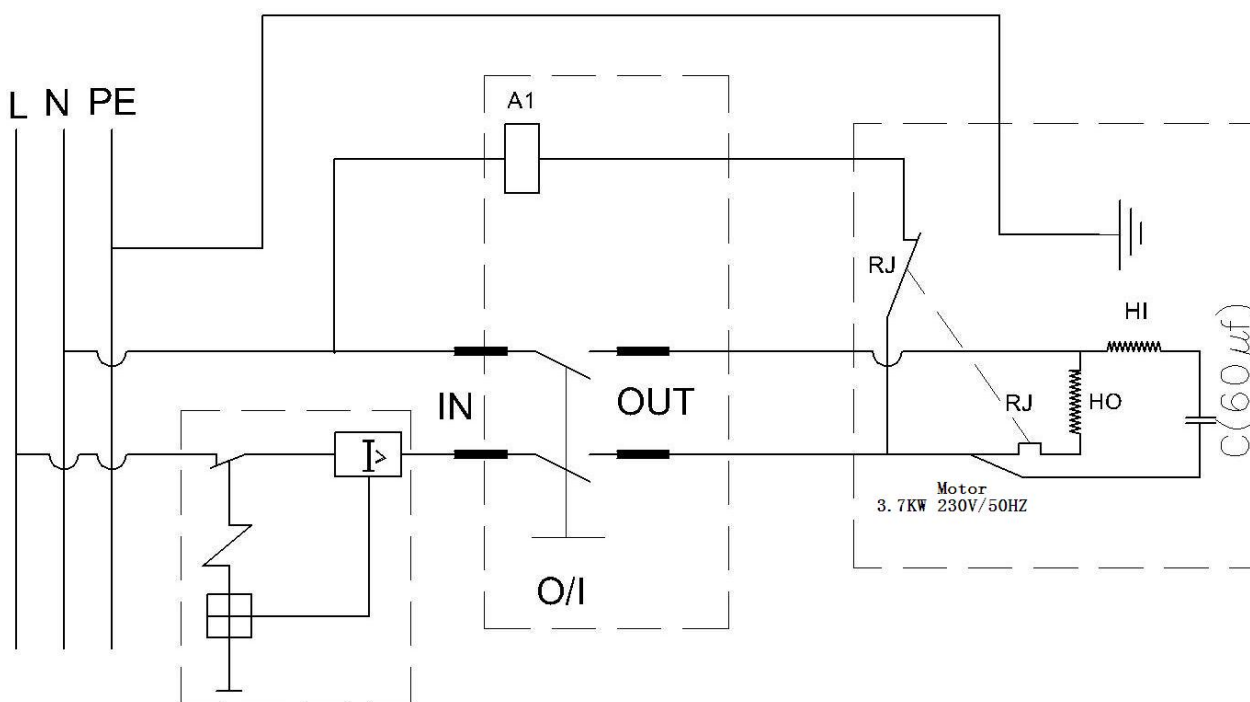

Hydraulic diagram

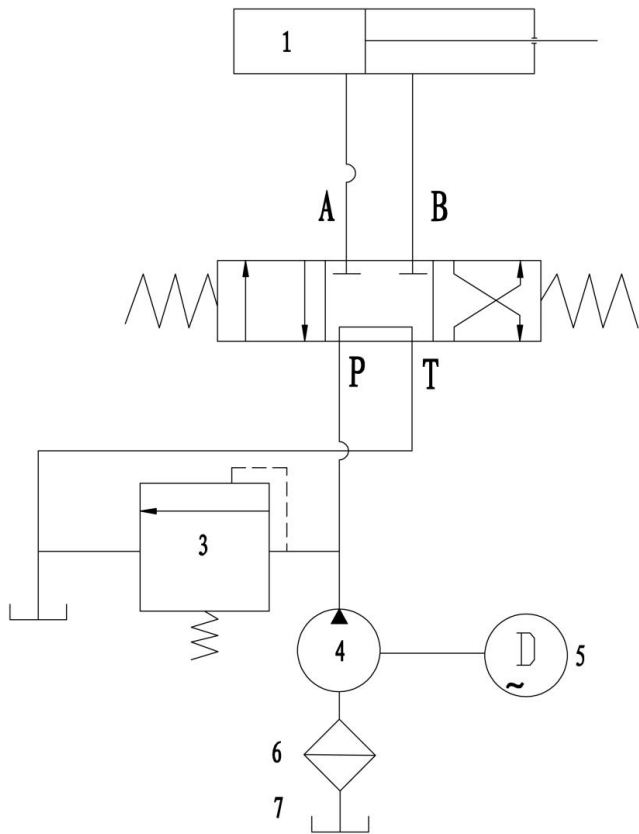

Introduction of parts

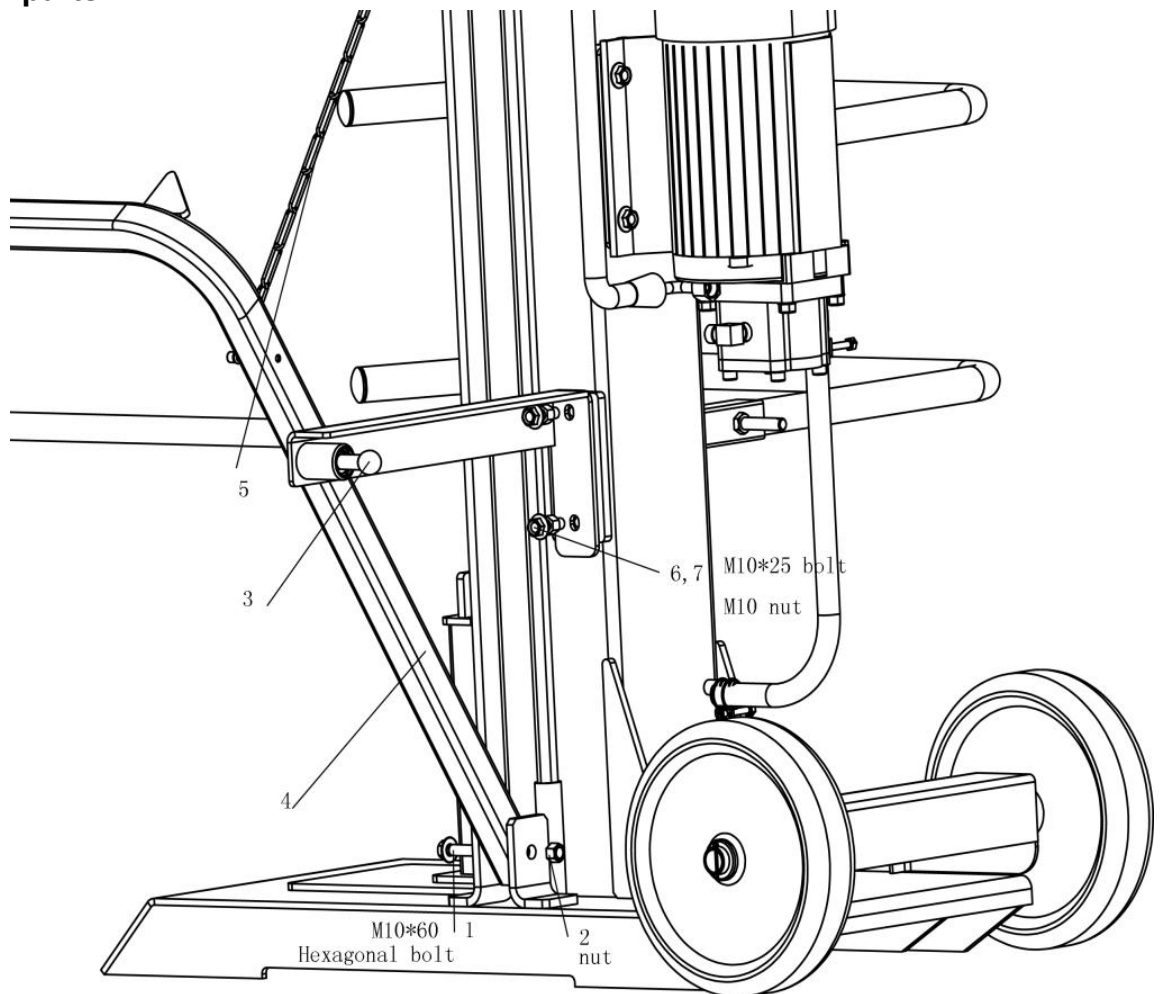

Fig1

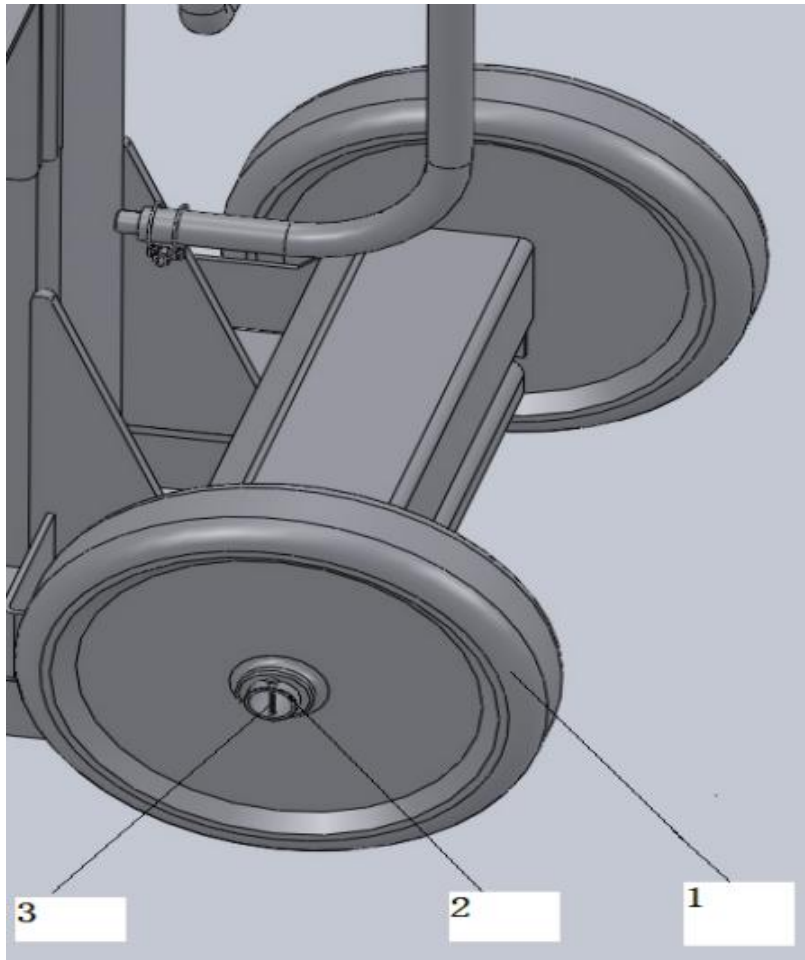

Fig2

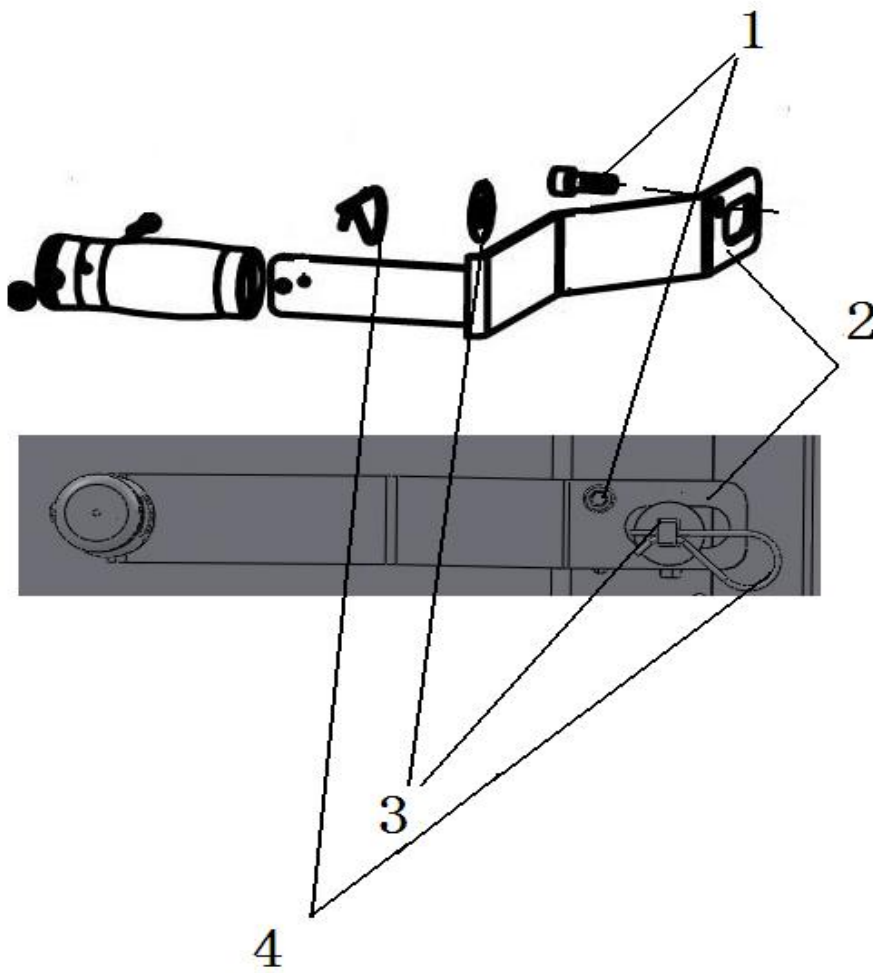

Fig3

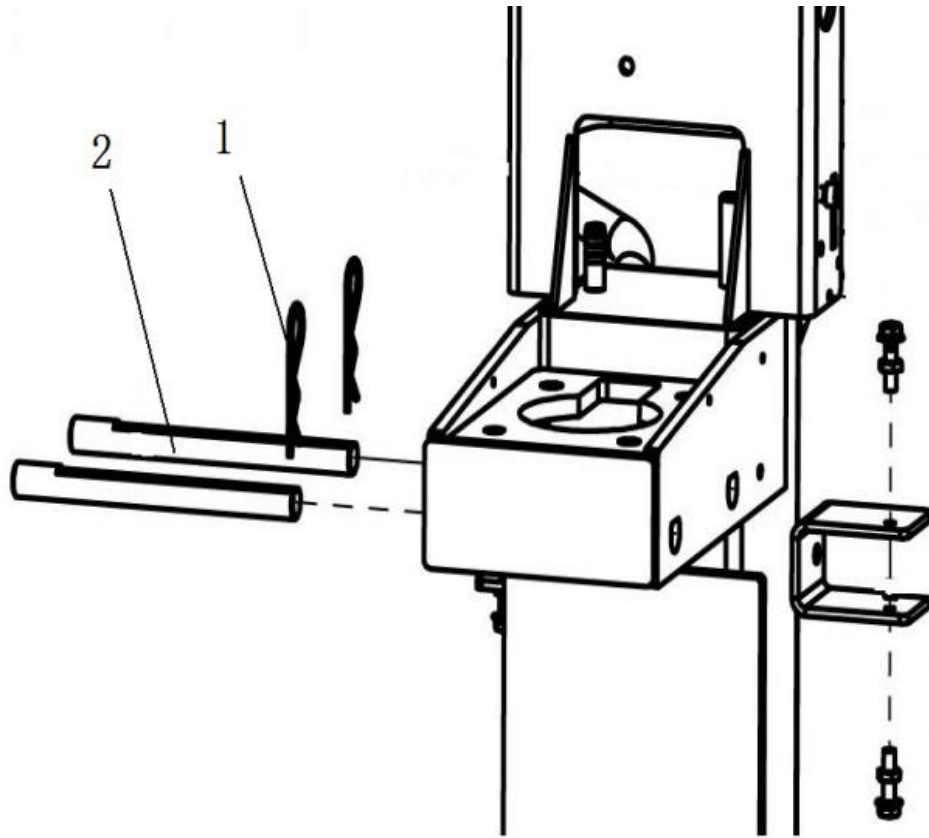

Fig4

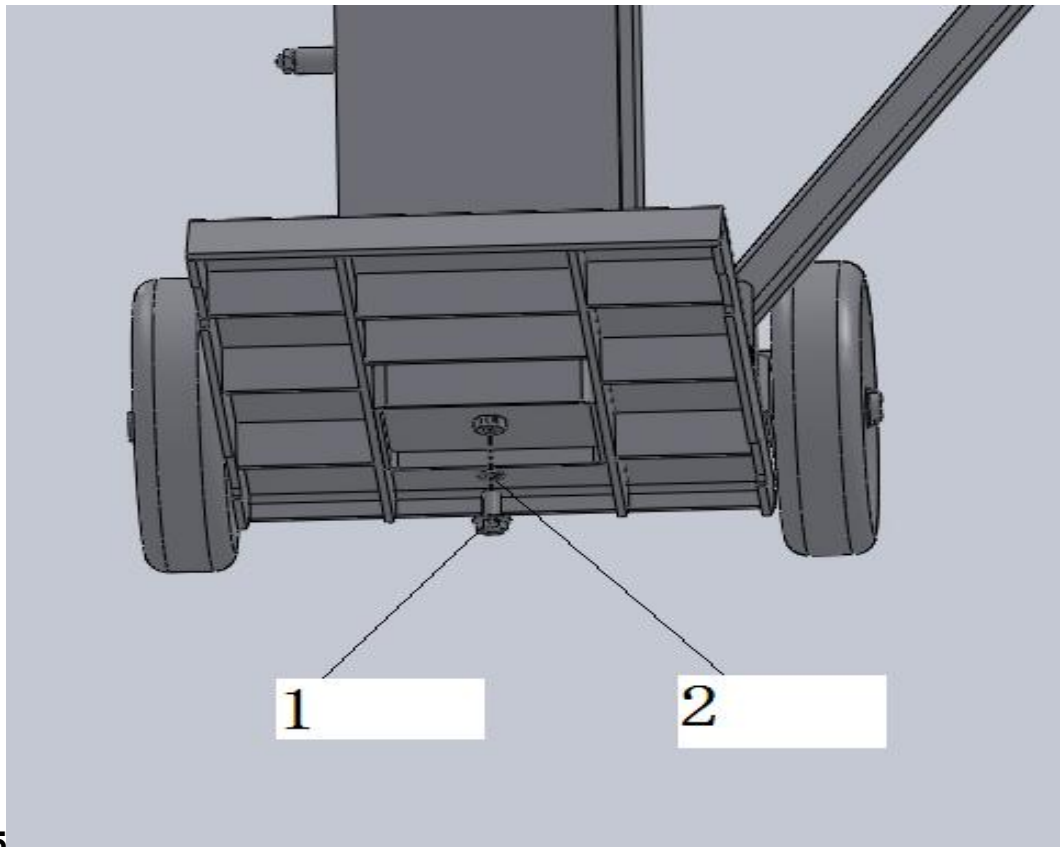

Fig.5

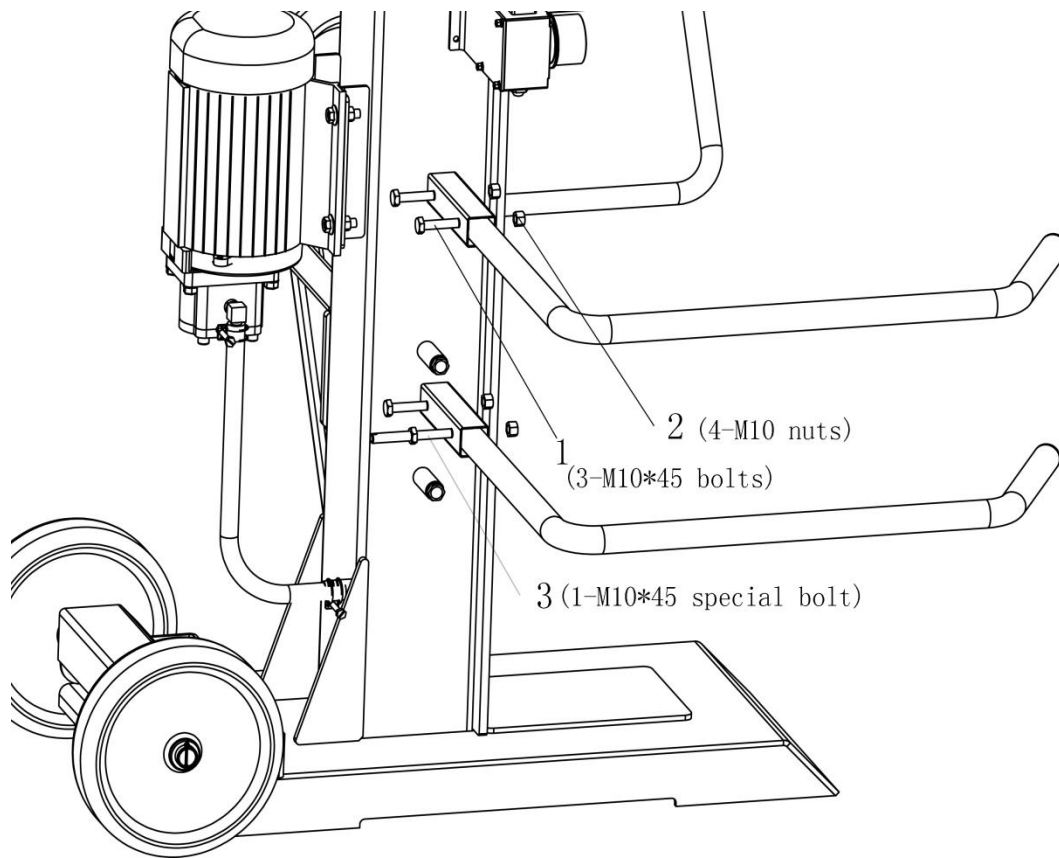

Fig.6

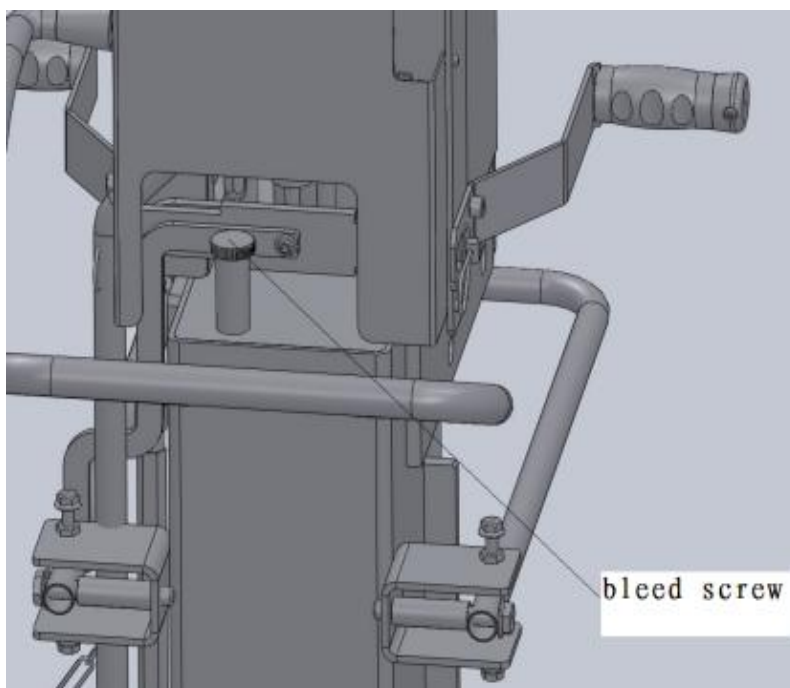

Fig.7

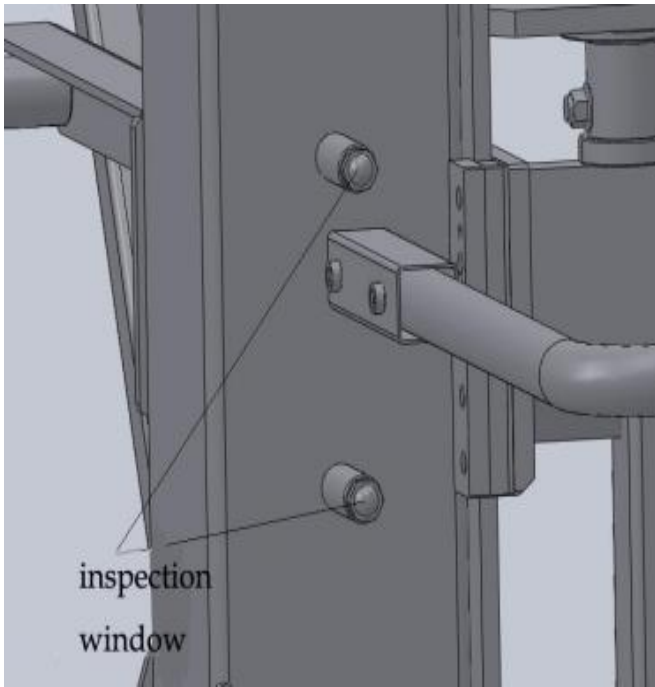

Fig.8

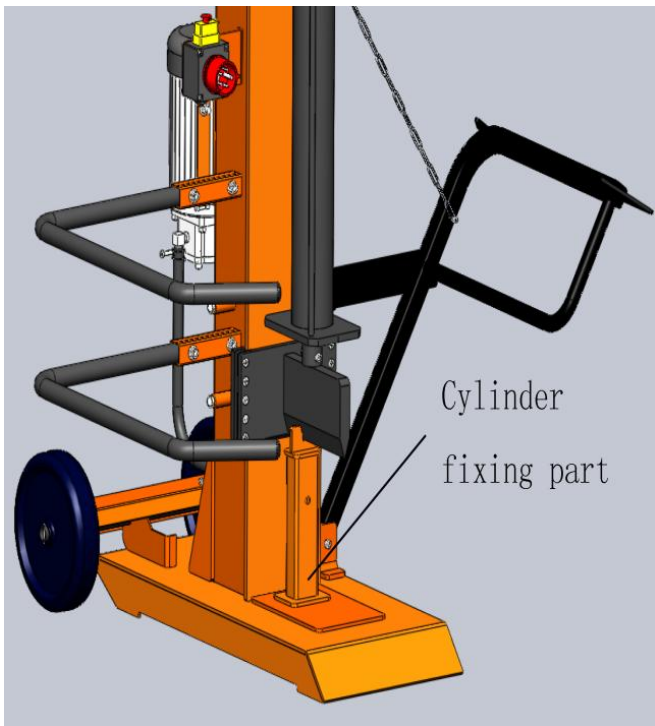

Fig.9

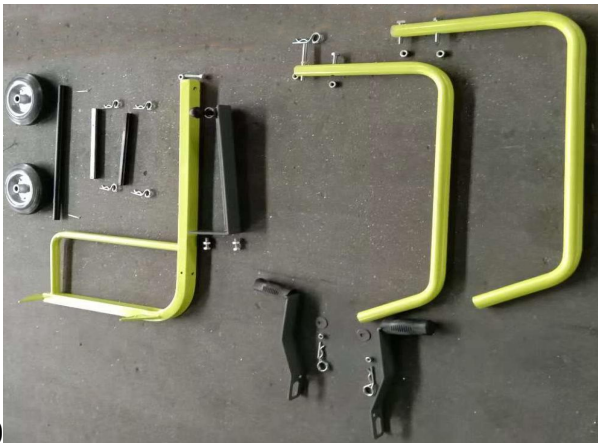

Fig.10

3. ASSEMBLY

Mount axle Fig.2

Insert axle through the hole in the base of splitter (No.2).

Assemble the wheels Fig.2

Place 2 wheels (No.1) on both sides of the axle and secure it with a cotter pin (No.3)

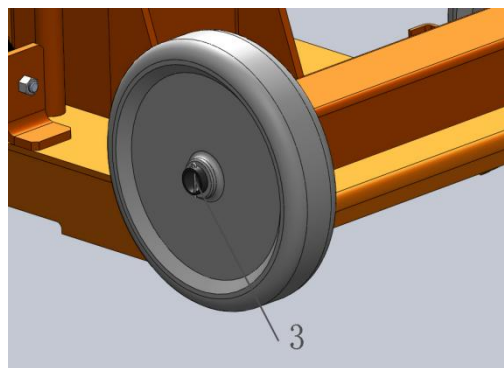
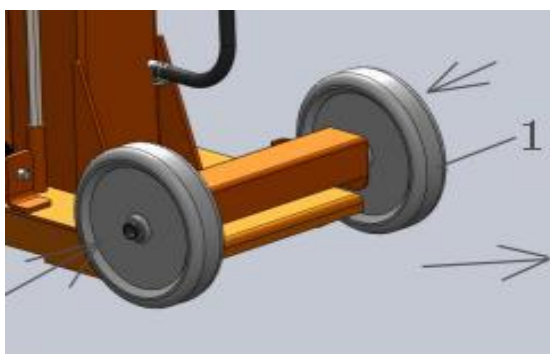
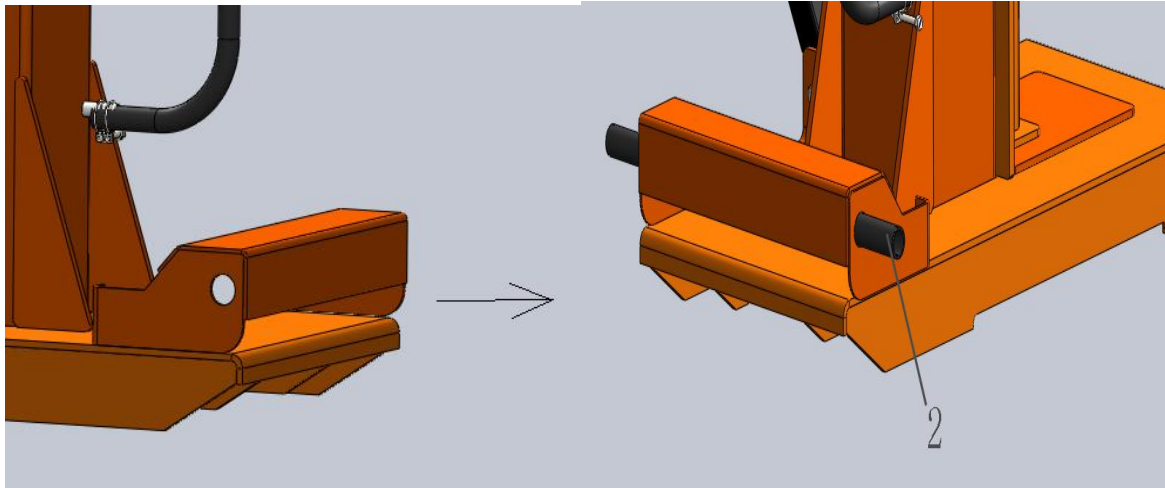

Assemble the control handle Fig.3

Because of packing reasons you must mount two control handles yourself. You can see it on the mounted control handle and at picture Fig.3 (with tool: 13-15 wrench)

According to the following steps:



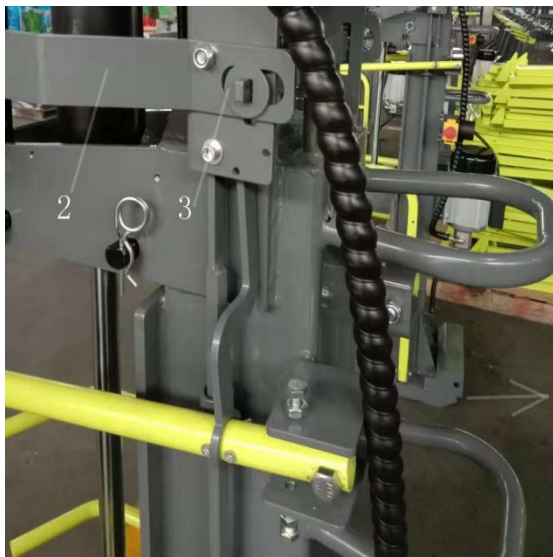

Assemble the support arm Fig.6

Fix two support arms with 3 bolts M10*45+1 long special bolt, and 4 nuts.(with tool:17-19 wrench)



Assemble the lifting device Fig.1

With 2 hexagonal bolts M10*25 and 2 nuts M10 to fix the support of lifting device. Then with 1 hexagonal bolts M10*55 and 1 nut M10 to connect the lifting device. Finally connect the chain.

Caution!

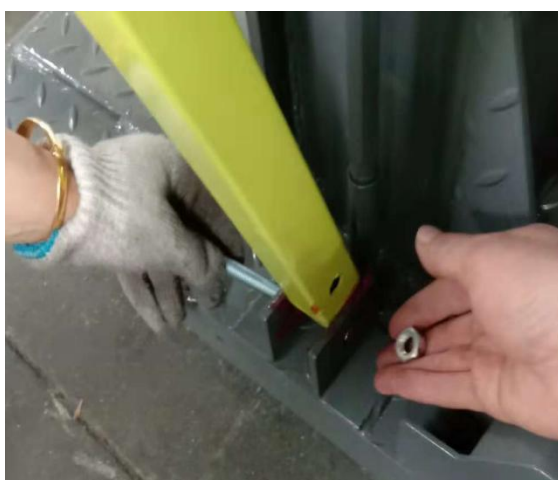

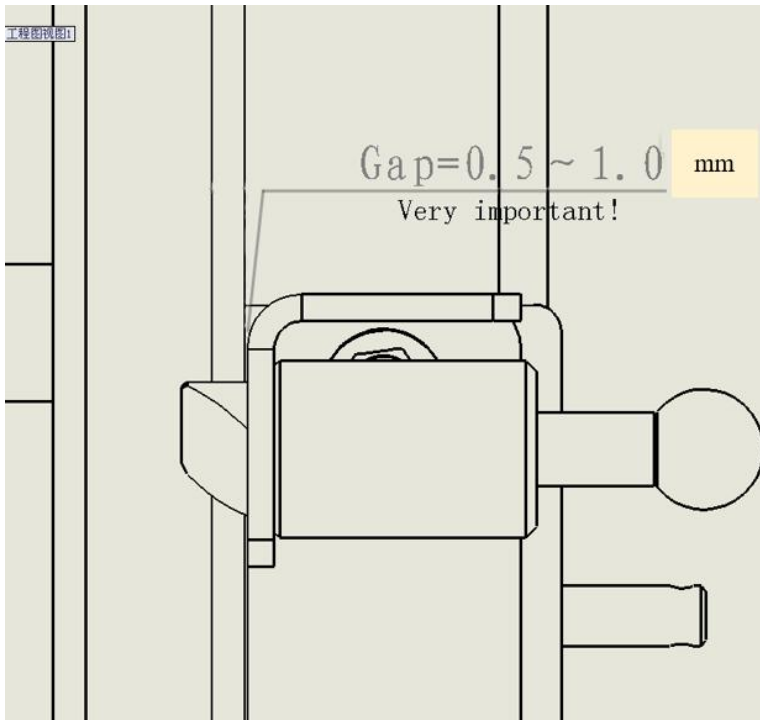

Manual handling

Transport by hand when transport, the cylinder must always be brought to the transport position. Fig.7 (the bleed screw must be sealed tight.)

To this end, move the splitter blade with slight pressure on the support. (E.g. wooden block)

Lower the cylinder by pressing the return bracket downwards or the handles upwards, but only to the extent that no connectors or cables are damaged.

Transport the log splitter.

Following transport, bring the log splitter to the working position, retract the support wheel and lock the cylinder in working position.

It is prohibited to work with the log splitter in a tilted transport position.

Function test

NOTE: Before each use, perform a function test.

Action	Result
Press both handles downwards.	Splitter blade goes down-up to about 18 cm above the base.
Press return bracket downwards or both handles upwards.	Splitter blade moves to the selected upper position.
Release the two handles	Splitter blade remains in the selected position.

4. OPERATION

Plan your work carefully. Pre-planning your work guarantees safety. Place the log such that it can be easily reached. Stack the split wood at a place nearby or load it onto a truck or other means of transportation. Place the log splitter on a firm, level surface.

If you slightly lubricate the wedge with grease before start-up, the service life of the splitter is extended.

Release the air from the hydraulic system before putting the log splitter in operation.

Loosen the bleed screw of the column tank by turning a couple of times until the air can flow in and out.

The draught of the oil tank should be detectable.

Before moving the log splitter, never forget to loosen the bleed screw (fig. 7)!

Otherwise, the air in the system is compressed and relaxed again and again, leading to the destruction of the seals of the hydraulic circuit and rendering the log splitter unusable. In this case, the seller and the manufacturer will dissociate themselves from any guarantee claims.

Switching on: Set the switch to ON position.

Switching off: Set the switch to OFF position.

Check the direction of run of the motor. When you turn on the motor, activate the splitting mechanism by moving both levers down.

If the splitter arm does not move after the machine is turned on, Please check the direction of the rotation of the motor immediately.

Place the log vertically on the support table, so that it lies flat on its face, and press it against the retaining pin.

To secure it. Make sure that the wedge and support table touch the end faces of the log completely. Never attempt to split the log at an angle. Move the splitter wedge down until the log is split.

Return the splitter wedge to the starting position by pressing the return bracket downwards or the handles upwards.

The splitting force and speed is regulated by a 2-step system.

The lower lever is generally meant for higher speed and lower splitting pressure to split normal wood (press both levers all the way down).

Push the control lever (2-manual operation) slightly upwards to achieve maximum splitting force and thus, a lower splitting speed for splitting freshly cut and hard wood.

The individual levels can be easily set up or down by slowly moving the lever.

It is prohibited to work with the log splitter in a tilted transport position.

Split the wood along the grain direction. Do not place the log to be split transversely on the log splitter. This can be dangerous and may seriously damage the machine.

Do not remove a firmly stuck log with your hands. You should never get the help of other people to remove firmly stuck log.

Piled up, split wood and wood chips can be dangerous. Never work in a messy work area in which you may slip, stumble or fall.

Use of the protective sleeve

The protective sleeve is height-adjustable in different stages, depending on the timber length.

Splitting at temperatures below 5 °C, allow the machine to run idle for about five minutes so that the hydraulic system reaches the operating temperature. Insert the log in an upright position under the splitter blade.

Note: the splitter blade is very sharp – risk of injury!

When you press the two levers down, the splitting blade moves down and splits the wood.

Split only logs that are cut straight.

Split logs in an upright state.

Never split logs that are lying down or across the grain direction!

When splitting wood, wear appropriate safety gloves and safety shoes.

In case of extremely overgrown wood, split the logs from the edge.

Note: certain woods can come under severe stress and rupture suddenly during splitting.

Knock out jammed wood against the cleavage direction or by moving the splitter wedge upwards. In this case, only press the handles upwards; do not use the return bracket. Note: risk of injury!

Stroke limiter

The stroke limiter is infinitely adjustable. For logs about 100 cm in length, set the socket at the top of the rod and lock it with the star grip.

Bring the log splitter to working position. Fig.4

Because of packing reasons the cylinder was descended in the lowest position, so after the engine is running, the cylinder must raise to working position.

Press two operation handles downward until the cylinder raise to the top of the machine, then insert two shafts(2)into the holes of the machine, and lock with two R-pins (1) to secure the cylinder on the machine.

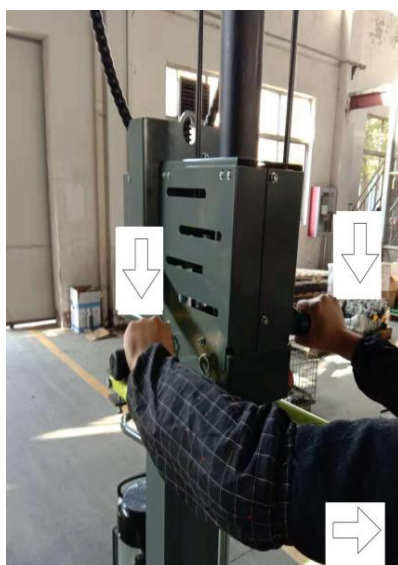

CAUTION!

Before delivery, while packing , the cylinder must be descended from top position to the lowest position, and fixed in the fixing part of the cylinder (Fig.9 cylinder fixing part).

According to the followings:

Press the two operation handles downwards, the riving knife begins to work forward ,until to the cylinder fixing part , release one operation handle, pull out two R-pins and two shafts(see Fig.4),then operate the two operation handles upward , the cylinder begin to descend, till to the proper position, release two operation handles, stop the machine, and put two shafts, two R-pins into the Accessories bag, finally remove the cylinder fixing part and insert it into long bolt then lock it with R-pin.

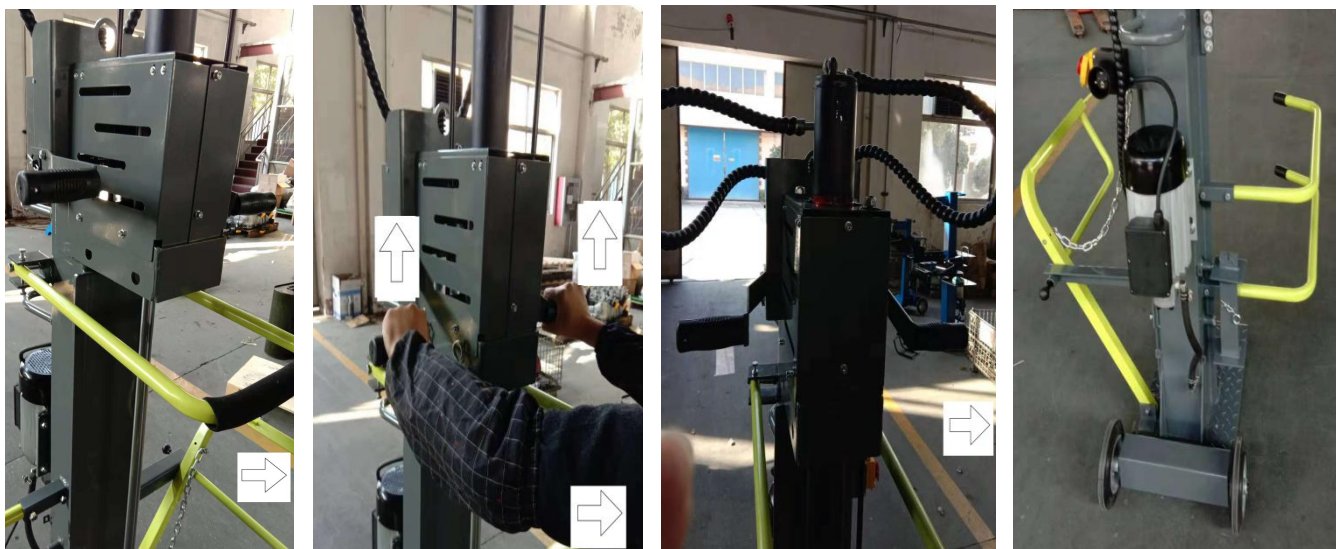

Stand assembly

Screws and spacers are used to fix the ground pin at the bottom of the machine, and then fix the machine by insert the ground pin into the two holes of the bottom of the stand and holes on the ground.

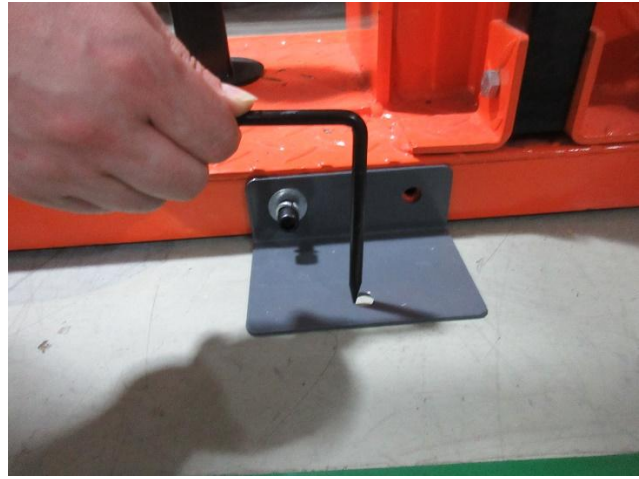

Operation of the log lifter

General information on log lifter:

The chain of the log lifter may be suspended only at the last link at the suspension plate for safety reasons.

Make sure that there are no persons in the work area of the log lifter.

Operation of the log lifter

Loosen the retaining hooks on the log lifter, so that the lifting rod can move freely

Move the splitter blade down until the lifting rod of the log lifter completely rests on the floor.

In this position, you can roll the log to be split onto the lifting rod

(The log must be in the area between the two fixing tips).

Press the return bracket down or the handles upwards and let the splitter blade go up. **(Caution! Do not stay in the work area of the log lifter! Risk of injury!)**

- Now set up the log, press it against the retaining pin and split it.
- Then, remove the split wood and move the splitting wedge, and thus the log lifter, down once again.
- Now, a new log can be rolled on the log lifter.

Resetting the log lifter.

When the log lifter is not in use, it is used as a second protective sleeve.

To this end, the protective sleeve is raised until it latches in the retaining hooks.

Transport position of the log lifter:

Guide the log lifter manually until it snaps into place. See **Fig.1**:

- 1-M10*55 hexagonal bolt
- 2-M10 nut
- 3-support arm
- 4-Lifting rod
- 5-chain

Follow these instructions to ensure fast and safe working

Electrical Connection

Check power supply cables regularly for damage. Make sure that the power cable is not connected to the mains supply when you check.

Electrical connections must comply with the relevant VDE and DIN regulations. Use only connecting cables with H 07 RN mark.

An imprint of the type designation on the power cable is mandatory.

The mains supply at the customer must be protected by an RCD (Residual Current Device) with a rated residual current of maximum 30mA.

Faulty power supply cables

Insulation damage often occurs on power supply cables.

Causes are:

Pressure points when power supply cables are routed through the window or door gaps.

Bends due to improper fastening or guiding of the power supply cables.

Cut points by running over the power supply cables.

Insulation damage by tearing from the wall outlet.

Cracks due to aging of the insulation.

Such defective power supply cables must not be used and are extremely dangerous because of the insulation damage!

Single -phase motor 230 V / 50 Hz

Mains voltage 230 V / 50 Hz

The mains connection and the extension cables must be 3-wire=P+N+SL. (L/N/PE).

The extension cables must have a minimum cross section of 1.5mm² and must not exceed a length of 20m.

The mains connection is fused for a maximum of 16 A.

Accident Prevention rules!

Refitting, adjustment and cleaning work may be performed only when the motor is turned off.

Disconnect the mains plug!

Skilled personnel may perform minor repairs to the machine.

Repair and maintenance work on the electrical system must be performed by qualified electricians.

All protective and safety equipment must be reassembled immediately after repair and maintenance work.

We recommend:

Clean the machine thoroughly after every use!

The splitter blade is a wear part that may have to be sharpened or replaced by a new one.

Two-hand control device the control device must remain easily accessible. Occasionally lubricate with a few drops of oil.

Moving parts - keep splitting blade guides clean (dirt, wood, chips, bark, etc.) - Lubricate sliding rails with spray, oil or grease several times a day. Never work uncertainly.

Check hydraulic oil level. The dipstick is at the bleed screw (**Fig. 8**)

Oil change

When do I change the oil?

First oil change after 50 hours,

Afterwards, every 250 hours.

Check the oil level.

Check the oil level regularly before each start.

Too low oil level may damage the oil pump.

Check hydraulic connections and fittings regularly for leaks. Tighten or replace, if necessary.

NOTE: the oil level should be checked with the splitter blade retracted. The oil lever can be checked

through the two inspection windows which are on the splitting column. If the oil level is at the lower window, this corresponds to the minimum oil level. If this is the case, oil should be refilled immediately. The upper window indicates the maximum oil level. The oil tank is in the splitting column and is factory-filled with high grade hydraulic oil.

Changing the hydraulic oil. Fig. 5.

Flip the splitter to the transport position (see Transportation/Storage)

Place an adequately large collector (minimum 15 liters) below the screw (No.1) at the splitting bottom.

Open the screw and drain the oil carefully into the collector.

Open the bleed screw at the upper side of the splitting column, so that the oil can drain off better.

Replace the screw with gasket (No.2) and tighten well.

Replace the splitter on the base plate

Fill with new hydraulic oil. (Content: see Technical Data) and check the oil level through the window.

After an oil change, press the log splitter several times without actually splitting.

CAUTION! Do not allow debris to enter the oil reservoir.

Dispose of waste oil properly in the local oil disposal site. It is forbidden to drain used oil into the ground or mix with solid waste.

We recommend the following hydraulic oils:

Q8 Haydn 46

Aral Vitam gf 22

BP Energol HLP-HM 22

Mobil DTE 11

Shell Tellus 22

or equivalent.

Do not use any other types of oil!

The use of other oils affects the function of the hydraulic cylinder.

Hydraulic system

The hydraulic system is a closed system with oil tank, oil pump and control valve

The prefabricated system must not be altered or tampered with.

Before starting maintenance and control measures, clean the work area and the appropriate tools should be kept ready in good condition.

The time intervals specified here refer to normal conditions of use; so, if the machine is heavily loaded, these times are reduced accordingly.

Clean the machine covers, screens and control lever with a soft, dry or slightly damp cloth using a neutral detergent; do not use solvents, such as alcohol or petrol, as they may damage the surface. Keep oils and greases out of the reach of unauthorized personnel; read the instructions on the containers carefully and follow them; avoid direct contact with the skin and rinse well after use. 22

Error Elimination

Fault	Possible Causes	Solution	Danger level
The hydraulic pump is not running	Voltage is absent	Check if the cables are live.	Risk of electric shock. This operation must be performed by a service Electrician.
	The motor thermal switch has turned off	Thermal switch turns on again after the motor cools down. Motor can be restarted.	
The column does not move down	Low oil level	Check the oil level and refill.	Risk of contamination. This operation can be Performed by the machine operator.
	2-hand operation incorrect	Check the attachment of the control lever.	Cutting hazard.
	Dirt in the column guide	Clean the column.	
Motor starts, but the column does not move down	Wrong direction of the motor With 3-phase current	Check direction of rotation of The motor and reverse it, if necessary.	Wrong direction of rotation can damage the pump.

5. MAINTENANCE AND REPAIRS

Any maintenance work must be performed by qualified personnel in strict accordance with these operating instructions. Before any maintenance procedures, you have to take all feasible precautions to stop the motor and disconnect the power supply (if necessary, pull out the plug). Attach a sign that explains the failure situation to the machine: "Machine out of service for maintenance: unauthorized persons are prohibited to stay at the machine and start it."

6. DISPOSAL



Electrical products should not be discarded with household products. According to the European Directive 2012/19/EU on waste electrical and electronic equipment and its implementation into national law, electrical products used must be collected separately and disposed of at collection points provided for this purpose. Talk with your local authorities or dealer for advice on recycling.

7. DECLARATION OF CONFORMITY



BUILDER SAS

ZI, 32 rue Aristide Bergès – 31270 Cugnaux - France

Tel: +33 (0)5.34.502.502 Fax: +33 (0)5.34.502.503

We hereby declare that the machine described below due to its design and construction as well as the model marketed by us, complies with the relevant regulations of the EC Directives listed below. In case of modifications to the machine, the present declaration loses its validity.

Designation of the machine: **ELECTRIC LOG SPLITTER**

Model: **HFBE10T105**

S/N: 20230507936-20230507977

Relevant EC directives:

Machine Directive 2006/42/EC

EMC Directive 2014/30/EU

ROHS Directive 2011/65/EU and 2015/863/EU

Applied harmonized European standards:

EN609-1:2017; EN60204-1:2018

EN55014-1:2017/A11:2020; EN IEC55014-1:2021

EN55014-2: 1997/A2:2008; EN IEC55014-2:2021

EN61000-3-2:2014, EN IEC61000-3-2:2019/A1:2021

EN61000-3-11:2000; EN IEC61000-3-11:2019

Cugnaux, 03/04/2023

A handwritten signature in black ink, appearing to read 'Philippe MARIE', is written over a faint circular stamp or watermark.

Philippe MARIE / PDG

This declaration of conformity is issued under the sole responsibility of the manufacturer.

8. WARRANTY

HYUNDAI

WARRANTY

The manufacturer guarantees the product against defects in material and workmanship for a period of 2 years from the date of the original purchase. The warranty only applies if the product is for household use. The warranty does not cover breakdowns due to normal wear and tear.

The manufacturer agrees to replace parts identified as defective by the designated distributor. The manufacturer does not accept responsibility for the replacement of the machine, in whole or in part, and/or ensuing damage.

The warranty does not cover breakdowns due to:

- insufficient maintenance.
- abnormal assembly, adjustment or operations of the product.
- parts subject to normal wear and tear.

The warranty does not extend to:

- shipping and packaging costs.
- using the tool for a purpose other than that for which it was designed.
- the use and maintenance of the machine done in a manner not described in the user manual.

Due to our policy of continuous product improvement, we reserve the right to alter or change specifications without notice. Consequently, the product may be different from the information contained therein, but a modification will be undertaken without notice if it is recognized as an improvement of the preceding characteristic.

READ THE MANUAL CAREFULLY BEFORE USING THE MACHINE.

When ordering spare parts, please indicate the part number or code, you can find this in the spare parts list in this manual. Keep the purchase receipt; without it, the warranty is invalid. To help you with your product, we invite you to contact us by phone or via our website:

- **+33 (0)9.70.75.30.30**
- **<https://services.swap-europe.com/contact>**

You must create a "ticket" via the web platform.

- Register or create your account.
- Indicate the reference of the tool.
- Choose the subject of your request.
- Describe your problem.
- Attach these files: invoice or sales receipt, photo of the identification plate (serial number), photo of the part you need (for example: pins on the transformer plug which are broken).



9. PRODUCT FAILURE

WHAT TO DO IF MY MACHINE BREAKS DOWN?

If you bought your product in a store:

- a) Empty the fuel tank if your product has one.
- b) Make sure that your machine is complete with all accessories supplied, and clean! If this is not the case, the repairer will refuse the machine.

Go to the store with the complete machine and with the receipt or invoice.

If you bought your product on a website:

- a) Empty the fuel tank if your product has one..
- b) Make sure that your machine is complete with all accessories supplied, and clean! If this is not the case, the repairer will refuse the machine.
- c) Create a SWAP-Europe service ticket on the site: <https://services.swap-europe.com> When making the request on SWAP-Europe, you must attach the invoice and the photo of the nameplate (serial number).
- d) Contact the repair station to make sure it is available before dropping off the machine.

Go to the repair station with the complete machine packed, accompanied by the purchase invoice and the station support sheet downloadable after the service request is completed on the SWAP-Europe site

For machines with engine failure from manufacturers BRIGGS & STRATTON, HONDA and RATO, please refer to the following instructions.

Repairs will be done by approved engine manufacturers of these manufacturers, see their site:

- <http://www.briggsandstratton.com/eu/fr>
- <http://www.honda-engines-eu.com/fr/service-network-page;jsessionid=5EE8456CF39CD572AA2AEEDFD290CDAE>
- <https://www.rato-europe.com/it/service-network>

Please keep your original packaging to allow for after-sales service returns or pack your machine with a similar cardboard box of the same dimensions.

For any question concerning our after-sales service you can make a request on our website <https://services.swap-europe.com>

Our hotline remains available at +33 (9) 70 75 30 30.



10. WARRANTY EXCLUSIONS

THE WARRANTY DOES NOT COVER:

- Start-up and setting up of the product.
- Damage resulting from normal wear and tear of the product.
- Damage resulting from improper use of the product.
- Damage resulting from assembly or start-up not in accordance with the user manual.
- Breakdowns related to carburetion beyond 90 days and fouling of carburetors.
- Periodic and standard maintenance events.
- Actions of modification and dismantling that directly void the warranty.
- Products whose original authentication marking (brand, serial number) has been degraded, altered or withdrawn.
- Replacement of consumables.
- The use of non-original parts.
- Breakage of parts following impacts or projections.
- Accessories breakdowns.
- Defects and their consequences linked to any external cause.
- Loss of components and loss due to insufficient screwing.
- Cutting components and any damage related to the loosening of parts.
- Overload or overheating.
- Poor power supply quality: faulty voltage, voltage error, etc.
- Damages resulting from the deprivation of enjoyment of the product during the time necessary for repairs and more generally the costs related to the immobilization of the product.
- The costs of a second opinion established by a third party following an estimate by a SWAP-Europe repair station
- The use of a product which would show a defect or a breakage which was not the subject of an immediate report and/or repair with the services of SWAP-Europe.
- Deterioration linked to transport and storage*.
- Launchers beyond 90 days.
- Oil, petrol, grease.
- Damages related to the use of non-compliant fuels or lubricants.

* In accordance with transport legislation, damage related to transport must be declared to carriers within 48 hours maximum after observation by registered letter with acknowledgement of receipt.

This document is a supplement to your notice, a non-exhaustive list.

Attention: all orders must be checked in the presence of the delivery person. In case of refusal by the delivery person, it you must simply refuse the delivery and notify your refusal.

Reminder: the reserves do not exclude the notification by registered letter with acknowledgement within 72 hours.

Information: Thermal devices must be wintered each season (service available on the SWAP-Europe site). Batteries must be charged before being stored.

HYUNDAI

POWER PRODUCTS



For inquiries, please contact:

BUILDER SAS

32 rue Aristide Bergès - Z.I. du Casque - 31270 Cugnaux - France

Tél.: +33(0)5.34.502.502 Fax.: +33(0)5.34.502.503

<http://www.hyundaipower-fr.com/>

Fabriqué en République Populaire de Chine(PRC)